

REV.	DESCRIPTION	DATE
1.0	Dennis	03/06/03
1.1	Dennis	10/22/04
1.2	Dennis	03/31/05

### SPECIFICATIONS

Current Rating: 1 Amps  
 Insulator Resistance: 1000 Megohms min.  
 Contact Resistance: 30 m ohms max.  
 Dielectric withstanding: AC 500V  
 Operating Temperature: -55°C~+105°C  
 Contact Material: Copper Alloy  
 Shell Material: Copper Alloy  
 Insulator Material: Polyester, UL 94V-0

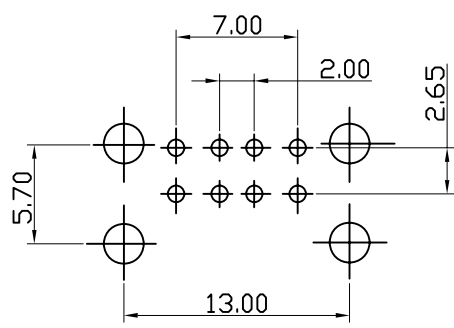
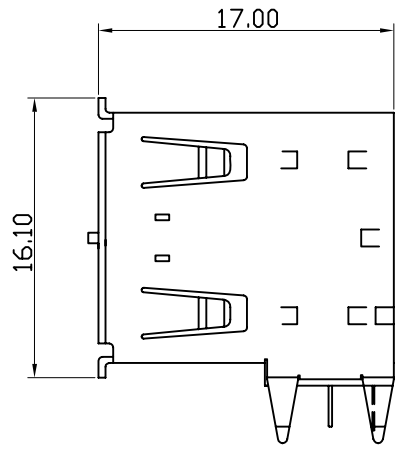
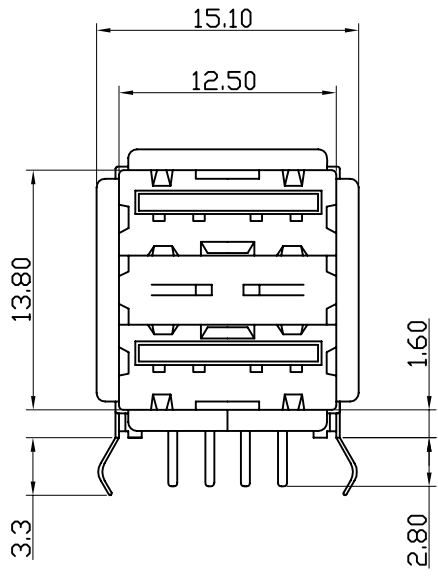

TOP VIEW  
PCB LAYOUT RECOMMENDED

BPOA-103-8-XXX-X-G  
 G: RoHS Compliant  
 Color: A=Black  
 D=White

Definition	Code
Gold Flash	V02
15μ" Gold	V55
30μ" Gold	V58
©Standard: V58	

APTOS Technology CONFIDENTIAL  
 This document, and all information it contains, are the confidential, proprietary property of APTOS Technology. Disclosure, duplication or distribution of this document, or any information it contains, in whole or part, without prior written permission from APTOS Technology is strictly prohibited

GENERAL TOLERANCE UNLESS OTHERWISE SPECIFIED	
XX. ± X	.XXX ± X
X. ± X	X.* ± X'
.X ± 0.25	.X' ± 3'
.XX ± 0.15	.XX' ± X'
REV. 02	DRAWN
DATE 03/31/05	CHECKED
SCALE 1:1	APPROVED
UNIT mm	SIZE A4



BPOA Series  
 Type A USB - Dual 90° Mount  
 PRODUCT NO. BPOA-103-8-XX-X\*  
 FILE NAME: BPOA 103 (90) LF APD.DWG